

Wadkin BURSGREEN

Wadkin Bursgreen WB 500x up cut Crosscut



Supplied by Advanced Machinery Services

Tel: 0844 844 9949

Fax: 0844 844 4744

www.advancedmachinery.co.uk

TABLE OF CONTENTS

GENERAL DESCRIPTIONS.....	1
WARNING LABEL LOCATIONS	2
WARNING LABEL (1).....	3
WARNING LABEL (2).....	4
SAFETY INSTRUCTIONS LABEL (3).....	5
CAUTIONS BEFORE OPERATING	6
OPERATION PROCEDURES	7
GENERAL SAFETY RULES FOR WOODWORKING MACHINERY WARNING.....	8
GENERAL SAFETY RULES FOR WOODWORKING MACHINERY WARNING.....	9
GENERAL SAFETY RULES FOR WOODWORKING MACHINERY WARNING.....	10
ADDITIONAL SAFETY RULES FOR CUT-OFF SAW	11
ADDITIONAL SAFETY RULES FOR CUT-OFF SAW	12
UNPACKING AND CHECKING CONTENTS	13
OPTIONAL EQUIPMENT	14
CLEANING THE MACHINE.....	15
MACHINE SPECIFICATIONS.....	16
CUTTING CAPACITY DIAGRAM 20” CUT OFF SAW.....	17
LEGEND OF 20” CUT- OFF SAW	18
ELECTRIC CONTROL SWITCHES	19
EMERGENCY STOP SWITCHES.....	20
INSTALLING MACHINE	21
CONNECT POWER WIRES	22
CONNECTING DUST COLLECTION SYSTEM.....	24
ELECTRIC WIRING DIAGRAM (1)	25

ELECTRIC WIRING DIAGRAM (2)	26
AIR CIRCUIT CONNECTION	27
AIR CIRCUIT DIAGRAM	28
MOUNTING INFEED AND OUTFEED CONVEYOR TABLE (OPTIONAL).....	29
MOUNTING INFEED AND OUTFEED CONVEYOR TABLE (OPTIONAL).....	30
LEVELING CONVEYOR TABLE TO MACHINE TABLE.....	31
ADJUSTING WORKING HEIGHT	32
SAWBLADE (OPTION)	33
REPLACING THE SAWBLADE (1)	34
REPLACING THE SAWBLADE (2)	35
ADJUSTING V-BELT TENSION (1).....	36
ADJUSTING V-BELT TENSION (2).....	37
REPLACING V-BELT	38
LUBRICATION	39
MAINTENANCE	40
FUNCTIONAL TEST	41
TROUBLE SHOOTING	42
SAFETY INTERLOCK SWITCH FUNCTION (CE SAFETY SWITCH).....	43
DIAGRAMS AND PART LISTS.....	44

GENERAL DESCRIPTIONS

Much thanks for our honorable customers whom to select our products, 20" Auto Hi-speed Cut-Off Saw. We deep believe your intelligent selection which will make you feel easy and satisfactory.

In order to assist you realize the machinery character and how to operate, maintain the machinery etc., affairs. Therefore, we compile this manual for you to study and refer. Of course, the products which before to deliver to the endorsers our company has made the necessary testing, measuring & practical operations. But it is essential to the machinery performance which is based on the accurate maintenance and operations. Since we wish our honorable customers must practiced operating method and maintenance regularly.

The manual is suggested to assist the user to understand the operating method much better and maintenance note precisely; moreover, to assure the supreme performance & long servicing life of machinery.

WARNING LABEL LOCATIONS



SAFETY INSTRUCTIONS

1. Read and understand the Operation Manual and all safety labels before operating this machine.
2. Only a trained person is to be permitted to operate this machine. Training should include instruction in operation under normal conditions and emergency situations.
3. This machine is to be serviced only by trained and authorized personnel. Follow lockout procedures before servicing.
4. Never reach into the machine for any reason unless the machine is at a COMPLETE STOP.
5. Never leave the machine stopped in such a manner that another worker can start the machine while you are working on or within the machine.
6. Never change or defeat the function of electrical interlock or other machine "shutdown" switches.
7. Before starting this machine, check that:
 - All persons are clear of the machine.
 - No maintenance work is being performed on the machine.
 - All guards are in place.
 - All parent rolls are well chucked in the unwind stands.
 - The machine is free of paper scraps, wraps and jams.
8. There is a potential hazard of entanglement in this machine caused by items such as long hair, loose clothing and jewelry. Make sure your clothing and hair fit closely to your body and that all jewelry, rings and watches are removed.

WARNING

Rotating blade hazard.

Do NOT operate with guard removed.

Lockout / tagout before servicing.

WARNING LABEL (1)



The warning label "KEEP HANDS CLEAR", shown as above, is attached to the sawblade front guard. It warns the operator to keep hands out of this area.



DANGER

WARNING LABEL (2)



The warning label "Rotating blade hazard". Do not operate with guard removed. Lockout/tagout before servicing", shown as above, is attached to side guard. It warns the operator do not operate the machine when the sawblade guard is opened.

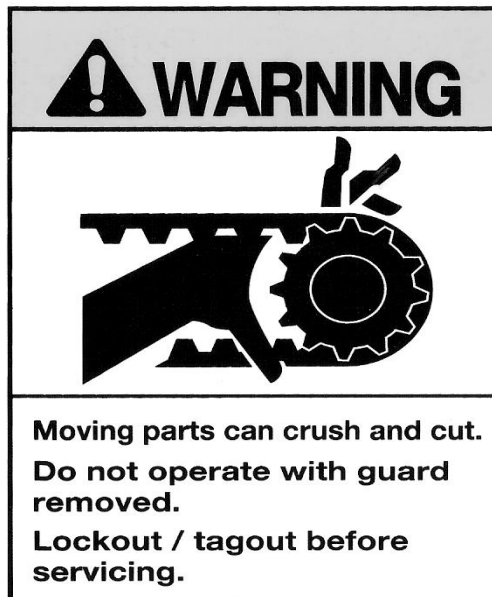

EM-001

SAFETY INSTRUCTIONS LABEL (3)

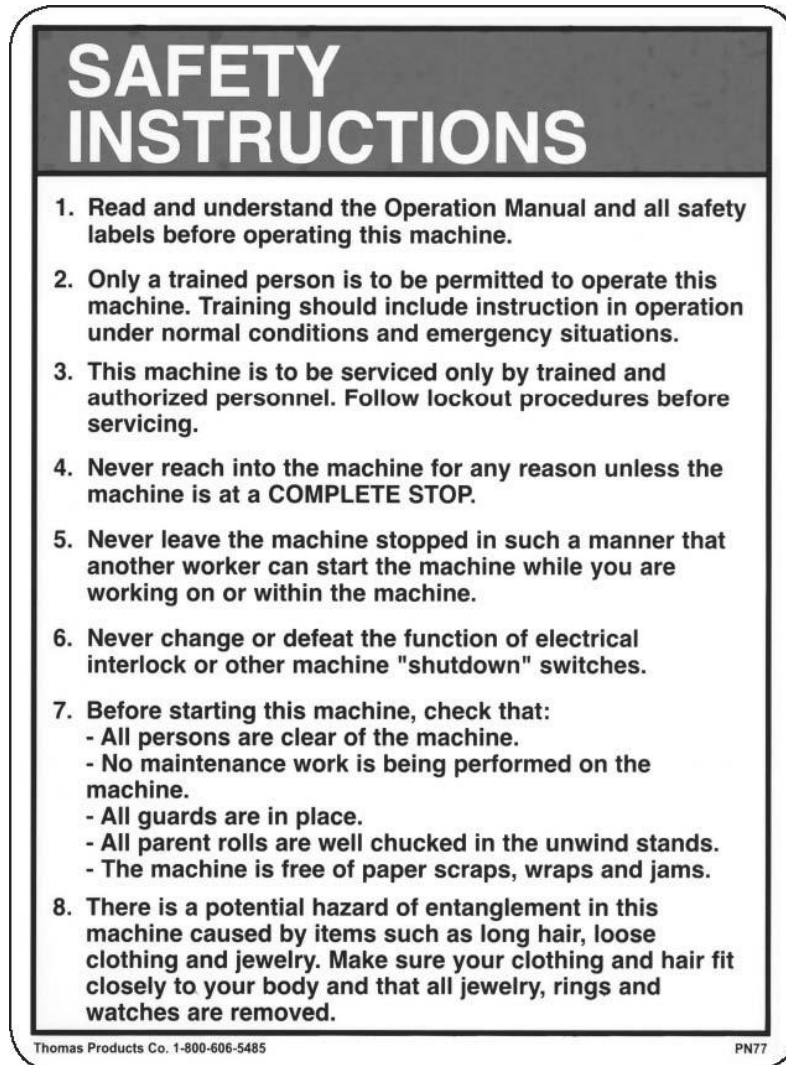

The label "SAFETY INSTRUCTIONS", shown as above, is attached to the front of cabinet. It gives safety instructions for operating the cut off saw.

CAUTIONS BEFORE OPERATING

1. This machine is designed for woodworking purpose (e.g. wood, polywood, composite wood, etc.).
It is prohibited to process any other materials of workpiece. (E.g. metal material, rubber / plastic material, alloy, etc.)
2. After the machine is transported to the installed site which must be cared to take off the exporting case and the install site must be flatten and rugged. If there are not flatten which can be inserted the shim at the bottom of the machine, so that there are not swung.
3. After the installed process is completed and then, which can be connected the power wire. Meanwhile, to inspect the rotating direction of circular saw is same as indicated or not. Check if there are not which must exchange the connecting terminal.
4. Before operating, firstly inspecting safety appurtenance, guard of saw blade- - - etc. and other safety device locked tightly or not.
5. In operating, operator shall stand away from the saw blade the tangent direction with rotate round; for fear that dust might get into eyes. And do not let hand nearness to the saw blade.
6. When workpiece jammed during operation, or necessarily to adjusting machine, please immediately stop the power.
7. To check the transmission “V” belt and the saw blade, when the phenomenon of the insufficient power occurred.

OPERATION PROCEDURES

1. Properly adjust the hold-down clamp according to the workpiece thickness.
2. To adjust hold-down clamp position, place a workpiece to be cut under the hold-down clamp, and adjust the hold-down clamp position by turning the adjustment knob. Normally the hold-down clamp position is adjusted to 1/4"~3/8" above the workpiece.
3. When the hold-down clamp is adjusted, remove the workpiece.
4. Start the sawblade running by pressing the blade start switch provided on the control panel.
5. Turn the AIR POWER SWITCH to on position.

GENERAL SAFETY RULES FOR WOODWORKING MACHINERY WARNING

	WARNING
<p>Do not attempt to operate until you have read thoroughly and understood completely all instructions, rules etc. contained in this manual. Failure to comply can result in accidents involving fire, electric shock, or serious personal injury. Keep this operation manual and review frequently for continuous safe operations.</p>	

1. Know your machine. For your own safety, read the operation manual carefully. Learn its applications and limitations, as well as specific potential hazards pertinent to this machine.
2. Don't remove the warning signs, markings, nameplates fixed on the machine.
3. Make sure the machine is properly grounded.

GENERAL SAFETY RULES FOR WOODWORKING MACHINERY WARNING

- 4.** Keep guards in place and in working order. If a guard must be removed for maintenance or cleaning, make sure it is properly reattached before using the machine again.
- 5.** Do not use in dangerous environments. Do not use machine in damp or wet locations, or expose them to rain. The work environment must be used adequate lighting. (Over 500 lux)
- 6.** Keep children away. All visitors should be kept at a safe distance from work area.
- 7.** Make workshop childproof with padlocks, master switches, or by removing starter keys.
- 8.** Do not force the machine. Do not exceed the maximum width and thickness of the workpiece. It will do the job better and be safer at the rate for which it was designed.
- 9.** Use the right tools. Do not force the machine or attachments to do a job for which they were not designed. Contact the manufacturer or distributor if there is any question about the machine's suitability for a particular job.
- 10.** Maintain machine in top conditions. Keep machine clean for best and safest performance. Follow instructions or lubricating and changing accessories.
- 11.** Use recommended accessories. Consult the operation manual for recommended accessories.

GENERAL SAFETY RULES FOR WOODWORKING MACHINERY WARNING

- 12.** Do not use machine while under the effects of drags, alcohol, or any medication.
- 13.** Keep proper footing and balance at all times.
- 14.** Disconnect machine from power source, before maintaining and when changing accessories, or when mounting and remounting motor.
- 15.** Avoid accidental starting. Make sure switch is in the "off" position before plugging in power cord.
- 16.** Check damaged parts. Before further use of the machine, a guard or other part that is damaged should be carefully checked to make sure that it will operate properly and perform its intended function. Check for alignment of moving parts, binding of moving parts, breakage of parts, mounting, and any other condition that may affect its operation. Guards or other parts that are damaged should be properly repaired or replaced.
- 17.** During indoor use the machine shall be connected to an external chip and dust extraction system. Make sure the dust extraction equipment is to be switched on before commencing machining. Always wear a face or dust masks if operates a lot of saw dust and or wood chips. Always operate the machine in a well ventilated area and provide for proper dust removal.
- 18.** Remove adjusting keys and wrenches. Form habit of checking to see that keys and adjusting wrenches are removed from the machine before turning it on.

ADDITIONAL SAFETY RULES FOR CUT-OFF SAW

1. All operators should read carefully and make sure they understand the details before starting operation and/or maintenance. For safety reasons un-trained operators are not allowed to operate the machine. Only operators adequately trained in the use, adjustment, and operation of the machine can handle the cut off saw.
2. Keep hands away the cutting area.
3. Always disconnect the power source before making any adjustments.
4. Do not operate the machine in case air pressure does not reach the normal working pressure. Normal working pressure for this cut off saw is 5kg/cm².
5. Make sure the height of the hold-down clamp is properly adjusted.
6. Make sure the saw blade running direction is correct.
7. Do not cut warped wood. The work piece must be sit flat on the table without rocking.

ADDITIONAL SAFETY RULES FOR CUT-OFF SAW

8. Never try to remove the cut-off piece until the power is off and saw blade has stopped.
9. Always use fence to position and guide workpiece. Do not use hands to support the work.
10. Do not exceed the maximum width and thickness of the workpiece for which the machine is designed.
 - * The maximum cutting capacity (thickness x width) for 20" cut off saw is
1" x 14.5", 2" x 14", 3" x 13", 4" x 12", 5" x 11"

UNPACKING AND CHECKING CONTENTS

The Cut-Off Saw and outfeed conveyor are separately packed in two wooden crates. In some cases, the infeed and outfeed conveyor table can be dismantled from the cut-off saw and packed together for saving shipping freight.

Carefully unpack the machine and ensure that all parts are present and free of damage. If any parts are missing or damaged, contact your local dealer immediately.

Do not attempt to assemble or operate the machine without all components present and in working order.

OPTIONAL EQUIPMENT

- Sawblade
- Infeed and outfeed roller conveyor, length as required.
- Safety guard

CLEANING THE MACHINE

After the machine is unpacked, remove the rust preventative oil that coats the machine with a cloth soaked in kerosene. Do not use gasoline or lacquer thinner, as this can damage the painted parts of the machine.

MACHINE SPECIFICATIONS

■ SPECIFICATIONS

NAME	20" CUT-OFF SAW
Cutting capacity (thickness x width)	1" x 14.5", 2" x 14", 3" x 13", 4" x 12", 5" x 11"
Cycle speed	40 strokes/ min
Cycle operation	Air
Saw blade size (optional)	20"
Saw arbor diameter	25.4mm (30mm/Option)
Saw blade speed	2800 RPM
Dust exhaust diameter	φ 4"
Motor	10 HP
Table size	660 x 747 mm
Net weight / Gross weight	355 / 415 kgs
Packing dimensions (L x W x H)	940 x 850 x 1350 mm
Noise level	83 dB

CUTTING CAPACITY DIAGRAM 20" CUT

OFF SAW

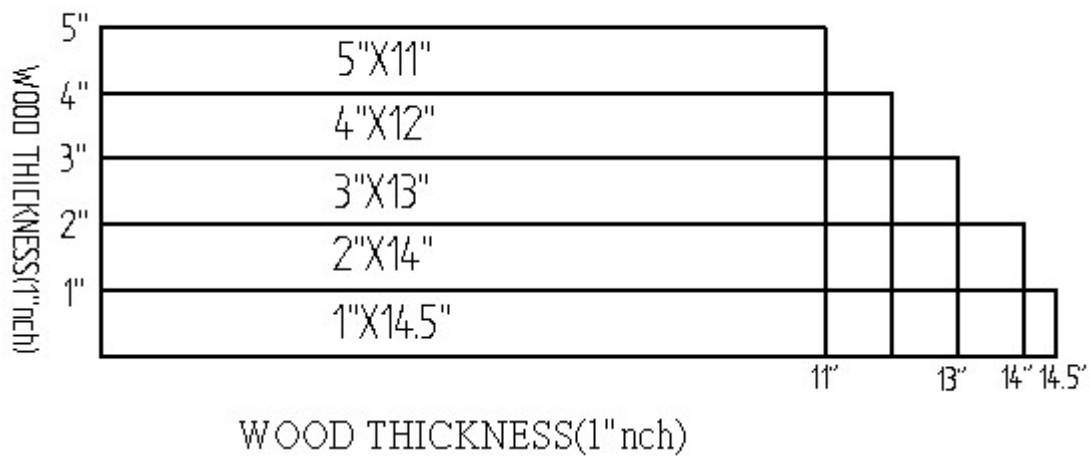

LEGEND OF 20" CUT- OFF SAW

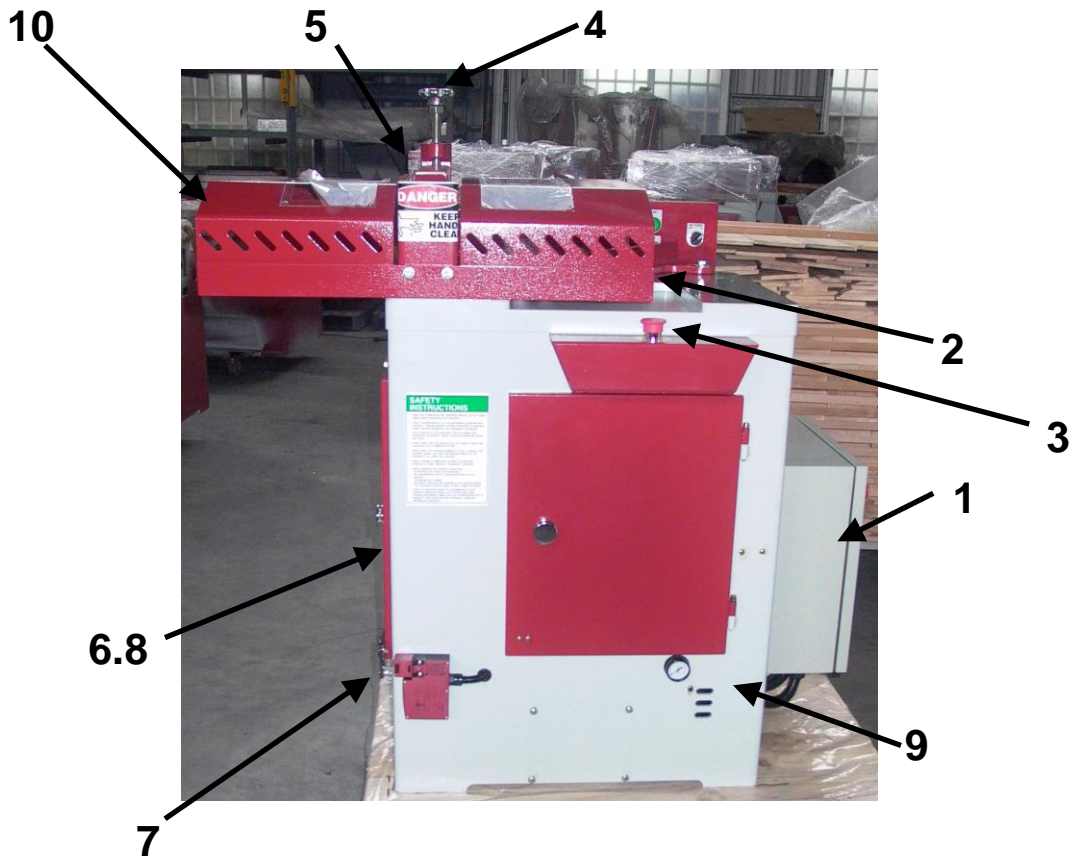

- | | |
|-----------------------------|-----------------------------|
| 1. Control panel | 6. Sawblade (optional) |
| 2. Fence | 7. Dust hood outlet |
| 3. Urgent return switch | 8. Saw blade door |
| 4. T clamp adjustment knob. | 9. Cabinet |
| 5. T clamp plate | 10. Safety protection cover |

ELECTRIC CONTROL SWITCHES

1. **SAWBLADE START SWITCH:**
Press this switch for starting the sawblade running.
2. **SAWBLADE STOP SWITCH:**
Press this switch for stopping the sawblade.
3. **AIR POWER SWITCH:**
Turn this switch to ON position, then air enters into the air circuit.
Turn this switch to OFF position for shutting off air pressure.

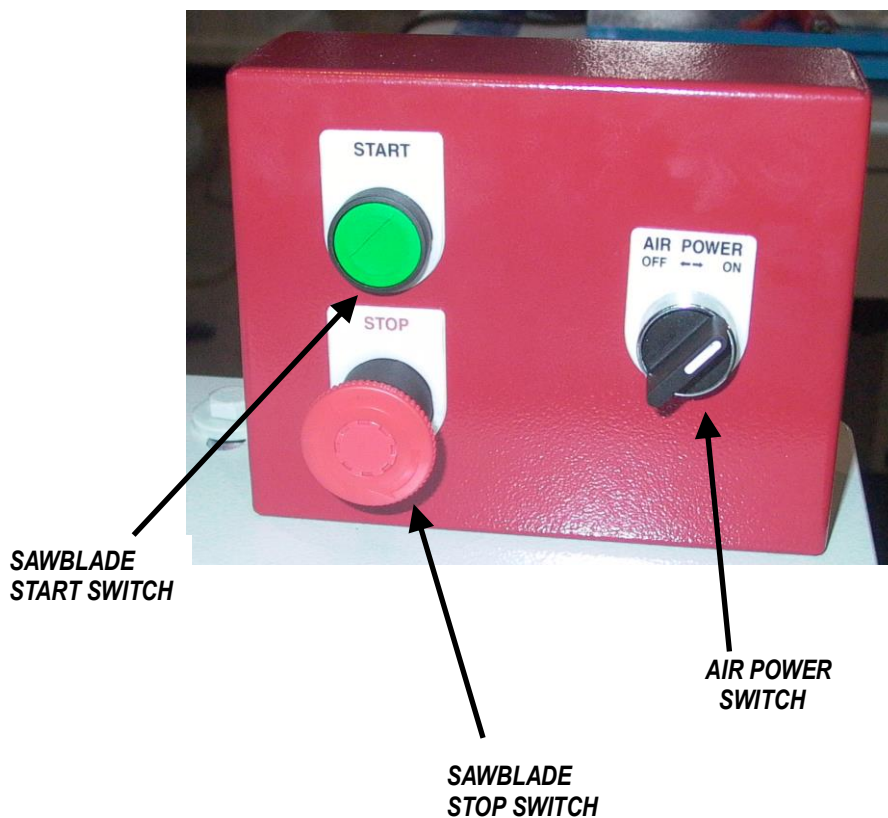

EMERGENCY STOP SWITCHES

This is an emergency stop switch for control system. When this switch is pressed, the machine stops immediately.

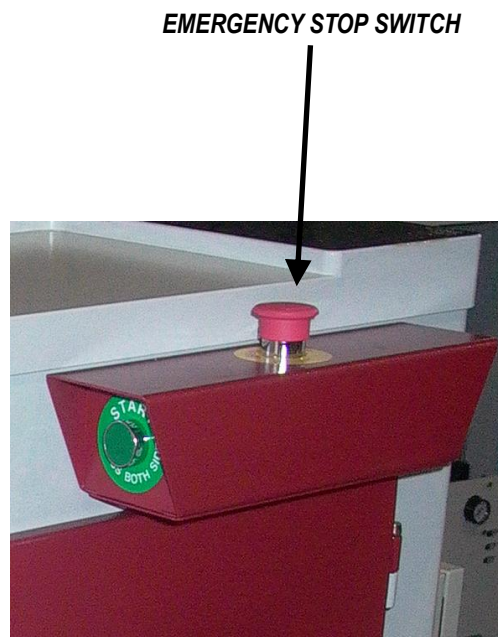

CAUTION

This emergency stop switch only shut off air power.

INSTALLING MACHINE

The cut-off saw does not need to be bolted into the concrete floor, however a solid and plan enough concrete floor is requested.

Leave proper space around the machine for conveniently handling the material to be cut.

Make leveling adjustment after the machine has been located at the work site.



CONNECT POWER WIRES

This machine has been factory wired according to the required voltage before shipment. When connecting this machine to your factory power source, be sure your power supply is the same voltage, hertz and phase as the machine pre-wired.

Connect the power wires to "R, S, T" contacts in the junction box, located at back side of the machine cabinet. After the power wires are connected, try to start the saw blade running by pressing the saw blade start switch, and then press the saw blade stop switch for immediately stopping the sawblade. At this time check to see if the sawblade runs to the correct direction as arrow sign indicated.

CONNECT POWER WIRES

If the saw blade runs to the direction as arrow sign instructed, then the power wires are correctly connected, otherwise you should change any two of the three power wires to obtain a correct running direction of the sawblade.

The machine should be properly grounded to avoid electric shock.



WARNING! Disconnect the machine from the power source before changing wires connection.

*SAWBLADE RUNNING
DIRECTION ARROW SIGN*



CONNECTING DUST COLLECTION SYSTEM

The cut off saw is equipped with a dust exhaust outlet, located at the left side of the machine. The dust exhaust outlet diameter is $\varphi 4"$. Use a proper diameter of flexible hose to connect the exhaust outlet to a dust collector.

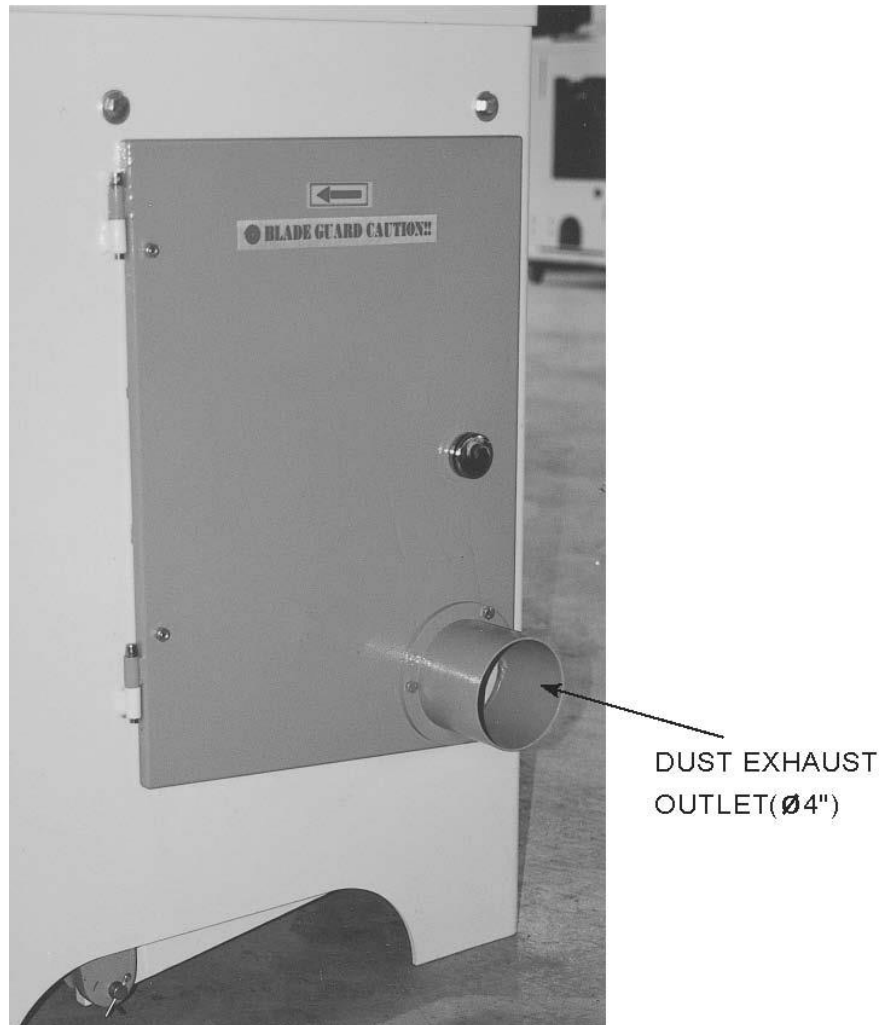

ELECTRIC WIRING DIAGRAM (1)

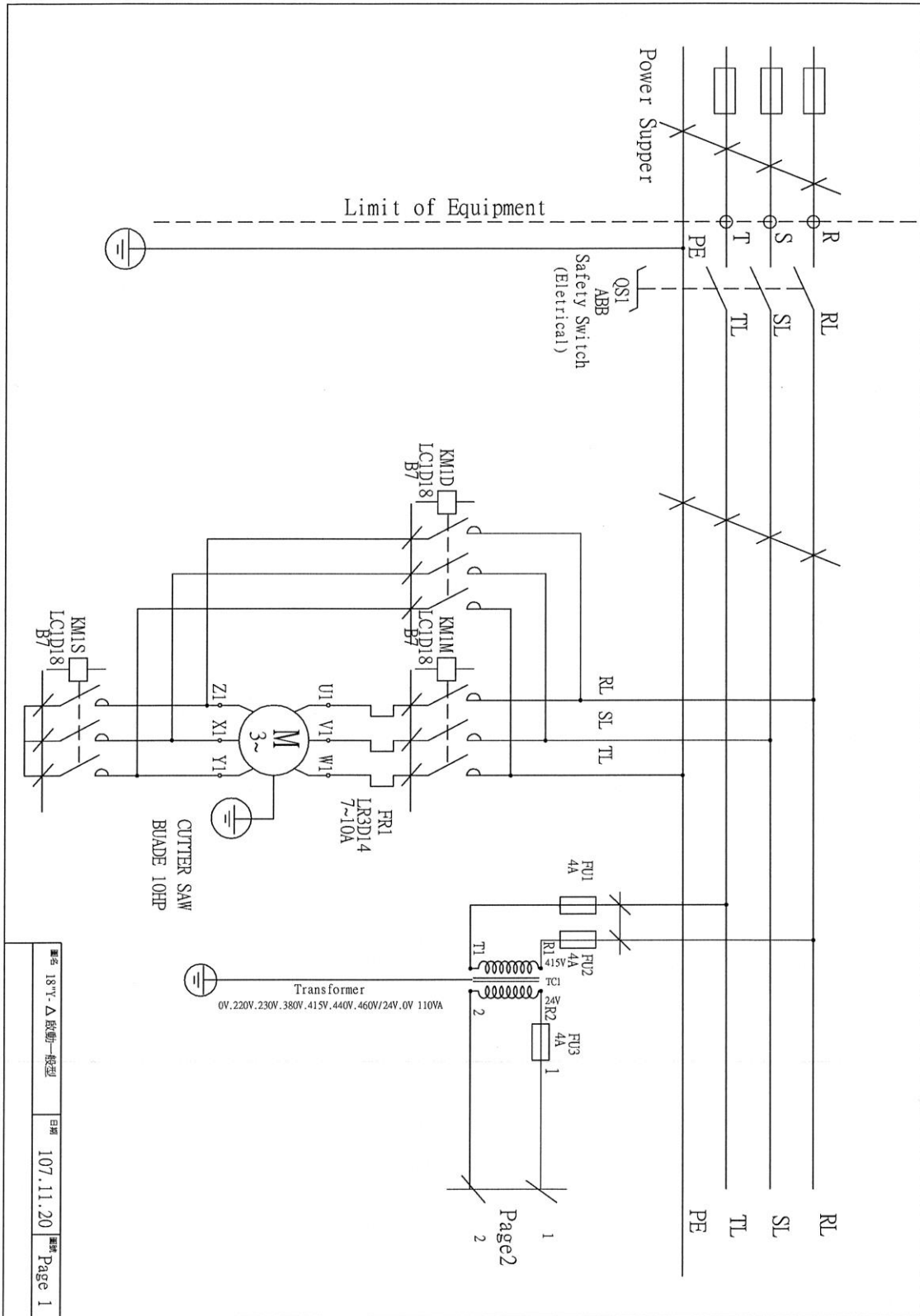

ELECTRIC WIRING DIAGRAM (2)

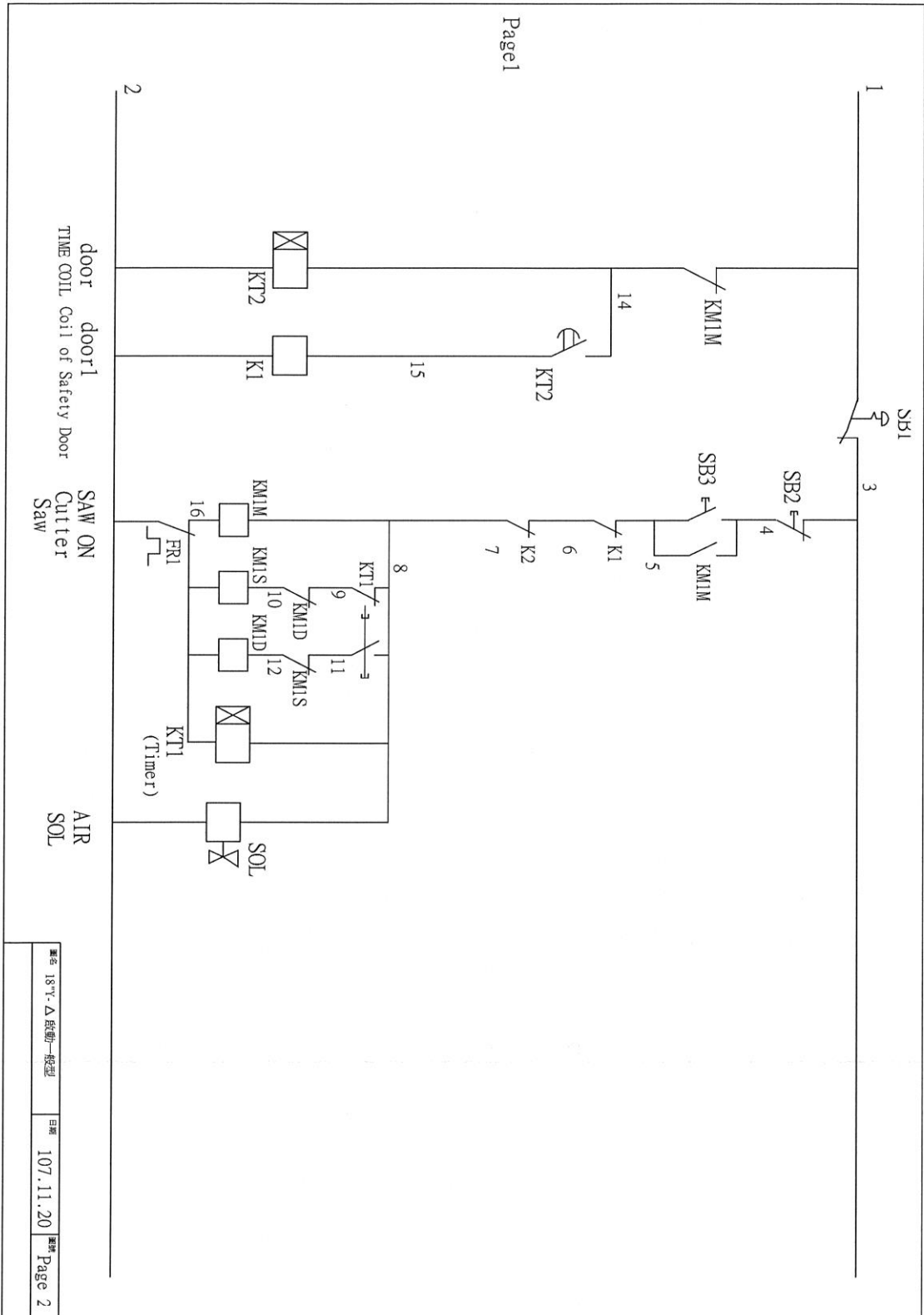

AIR CIRCUIT CONNECTION

The quick air connector is provided on the Filter/Regulator/Lubricator unit; simply connect the air source to the air connector.

The Filter/Regulator/Lubricator unit (F.R.L. UNIT) is mounted at the front right side in the cabinet. Open the front door you can find it. The working pressure is indicated on pressure gauge of F.R. L unit. The correct working pressure should be adjusted to 5-6 kg/cm² range. To adjust working pressure simply turn pressure adjust knob. Turn the knob clockwise for increasing pressure, turn knob counter-clockwise for reducing pressure.

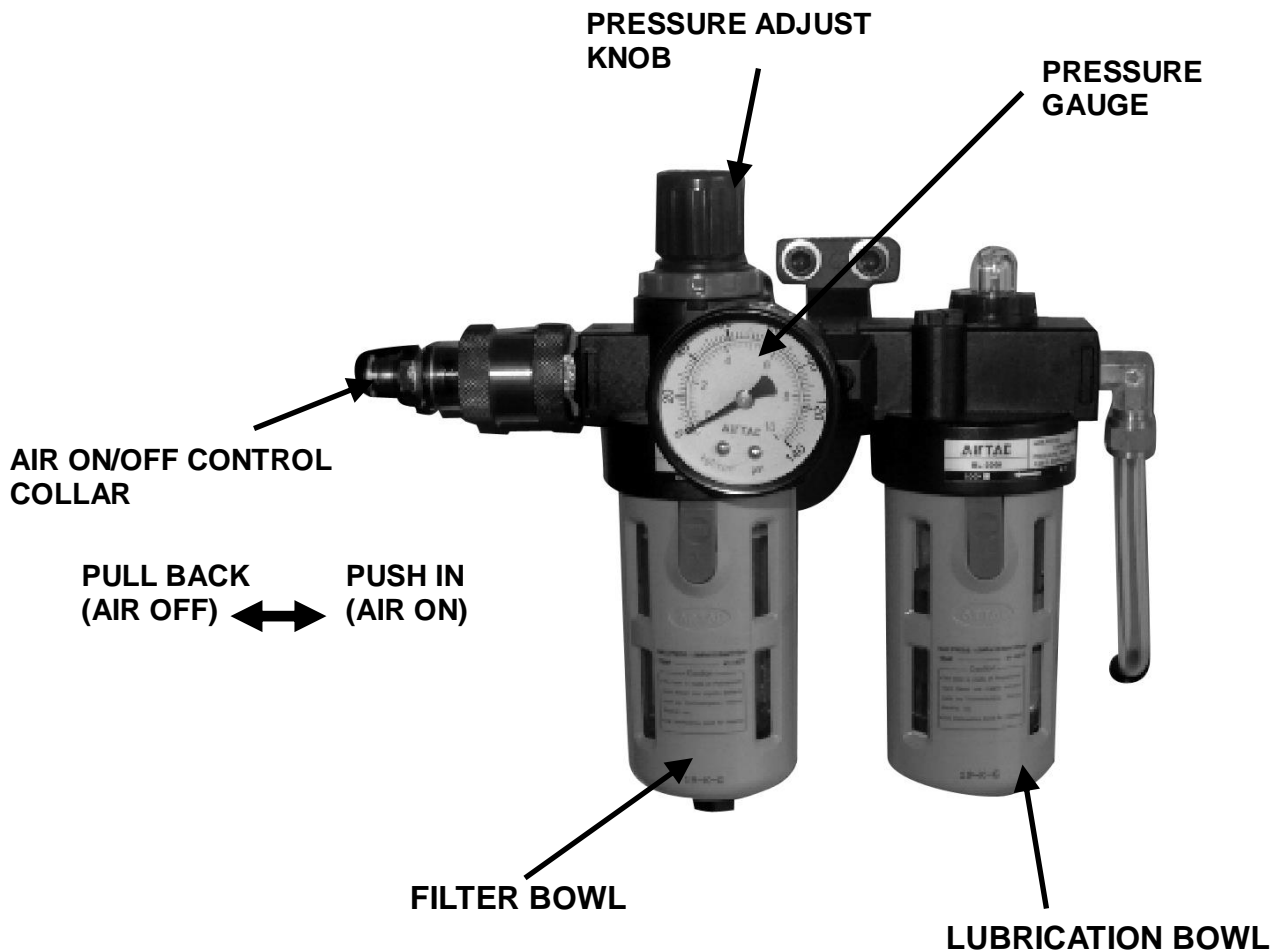

AIR CIRCUIT DIAGRAM

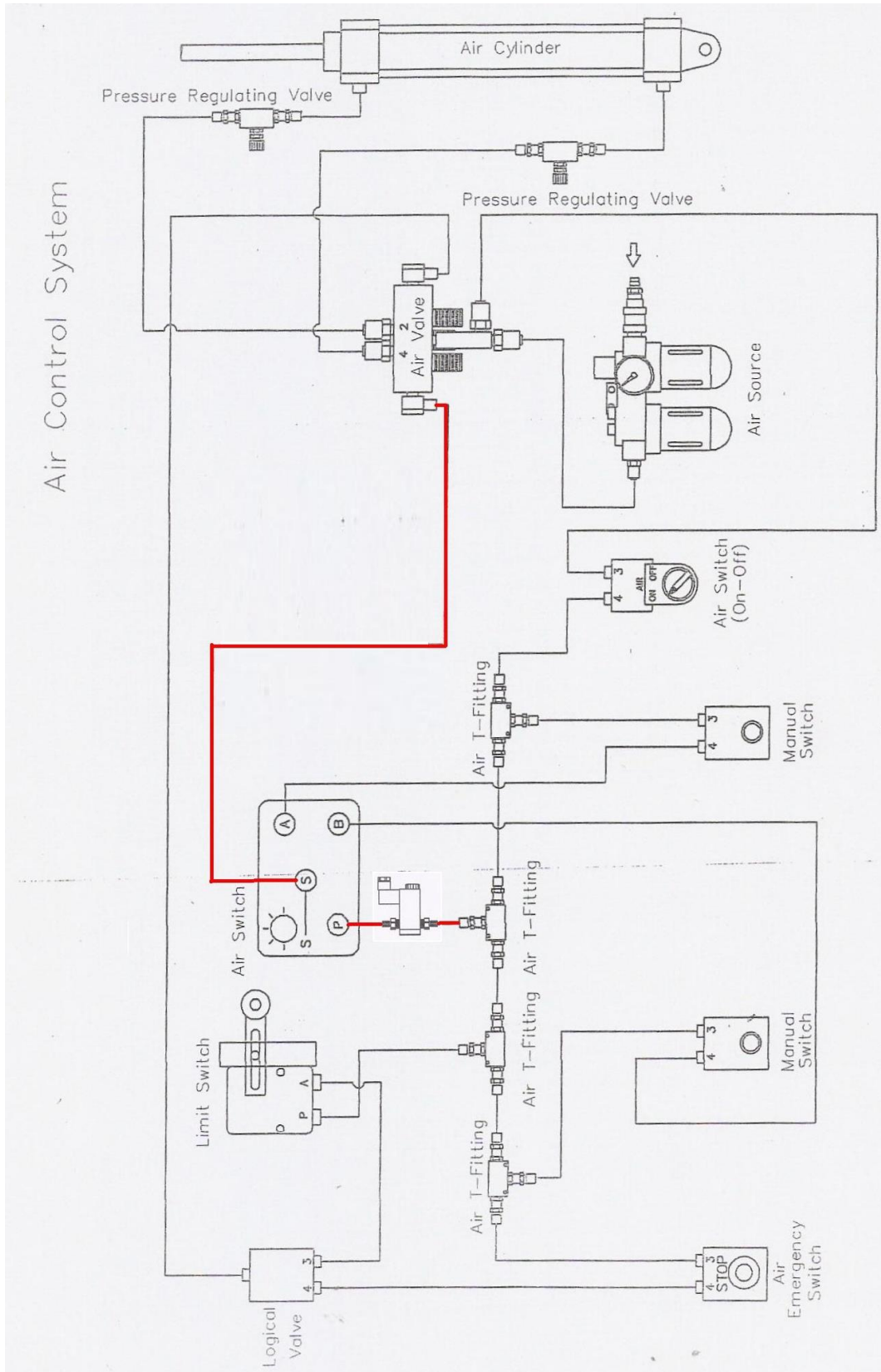

MOUNTING INFEED AND OUTFEED

CONVEYOR TABLE (OPTIONAL)

1. The instructions below are for mounting the infeed and outfeed conveyor table. Mounting procedures for infeed and outfeed conveyor table are the same.
2. When mounting the infeed and outfeed conveyor, ask another one to help you for moving the conveyor table.
3. Assemble the conveyor table support plates on the infeed and outfeed side of the cabinet. Note that the surface of support plate with two slots should be located horizontally and the surface with 4 slots should be located vertically. At this time only slightly tighten the support plates.
4. Place the infeed conveyor table on the support plate. Align the two holes on the end of the infeed conveyor table with the two horizontal slots on the support plate. And slightly tighten the infeed conveyor table.

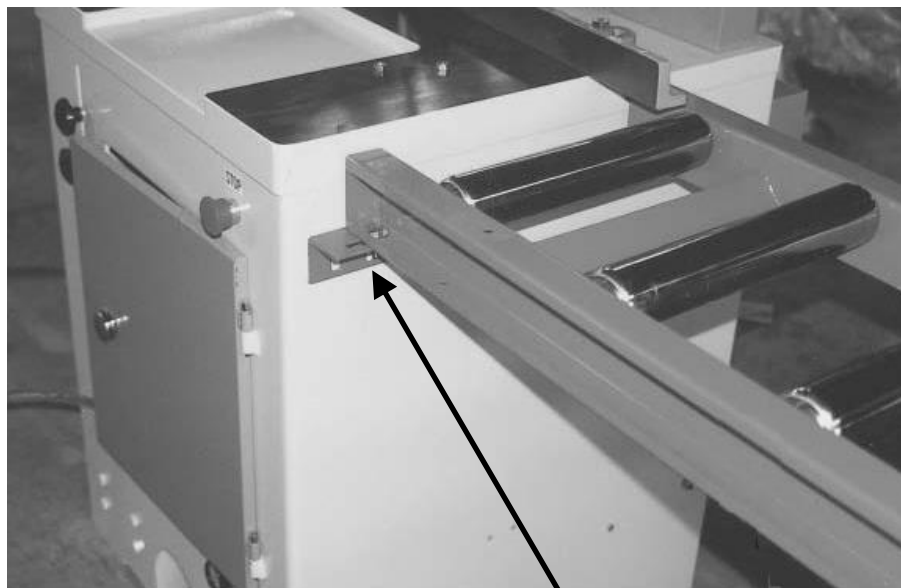

**CONVEYOR TABLE
SUPPORT PLATE**

MOUNTING INFEED AND OUTFEED CONVEYOR TABLE (OPTIONAL)

5. After the infeed conveyor table has been mounted, be sure to make conveyor leveling adjustment to table surface.
6. Place a straight edge on the table surface across the conveyor roller; raise the conveyor table until the roller just touches the straight edge. Then tighten the lock screws.



MACHINE TABLE

CONVEYOR ROLLER

STRAIGHT EDGE

7. The entire conveyor table leveling should also be properly adjusted. Turn the leveling screws located under the legs for leveling adjustment.

LEVELING CONVEYOR TABLE TO MACHINE TABLE

1. Leveling adjustment for the infeed and outfeed conveyor table are the same.
2. Place a straight edge across the machine table and infeed conveyor roller.
3. Raise the infeed conveyor table until the conveyor roller just touches the straight edge.

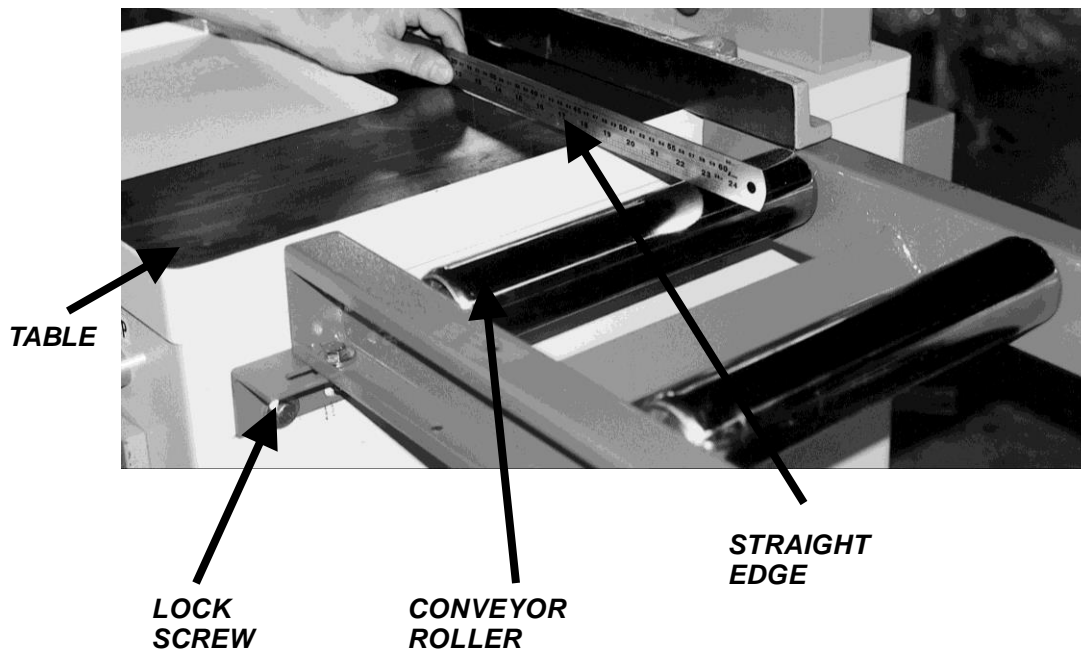

4. Tighten the two screws securely that fasten the infeed conveyor table to the cut-off saw.
5. Repeat above procedures to level the outfeed conveyor table.

ADJUSTING WORKING HEIGHT

1. Raise the hold-down clamp by pushing in the AIR ON/OFF control collar on the quick air connector.
2. Place a workpiece to be cut under the hold down clamp.
3. Turn the height adjustment knob to raise or lower the hold down clamp.
If you feel heavy to turn this knob, pull back the AIR ON/OFF CONTROL COLLAR (air off) for effortless turning of the knob.
4. Normally the hold-down clamp is adjusted so that its bottom is about above the workpiece.
5. After the hold down clamp is adjusted, tighten the lock nut.



SAWBLADE (OPTION)

NOTE: The cut-off saw accommodates 20" diameter sawblade.

1. Only correctly sharpened saw blades manufactured according to EN 847-1:1997 are used.
2. The suitable sawblade is a 20" diameter carbide tipped blade.
20" sawblade: Teeth number is 120.

Blade bore size is 25.4mm or 30mm(option) diameter.

3. The sawblade should cycle under the maximum safe operating speeds.
For 20 " sawblade, the cycle speed should not exceed the maximum safe operating speed of 2700-2800 RPM or greater.
4. Always keep the sawblade sharp for normal cutting quality. Sharpen the sawblade immediately in case it is worn out.

REPLACING THE SAWBLADE (1)

1. Disconnect the machine from the power source.
2. Open the left side door. Use the supplied door handle to turn the door latch for opening the door.
3. Loosen the sawblade lock screw by using the supplied "T" wrench.

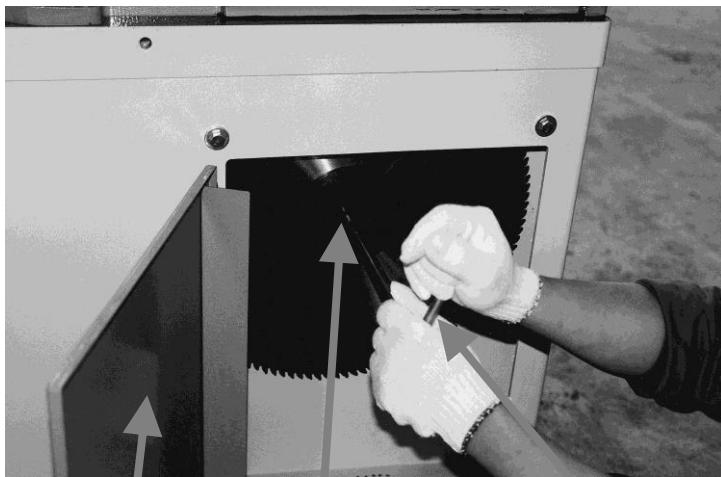

LEFT SIDE DOOR *BLADE LOCK SCREW* *"T" WRENCH*

4. Remove sawblade lock screw and flange. Take out the old sawblade.



SAWBLADE *FLANGE*

REPLACING THE SAWBLADE (2)

5. Press up the SPINDLE LOCK UNIT to lock the spindle for fitting a sawblade onto the arbor. Ensure that the arbor and flange are clean of dust and debris before fitting the saw blade.

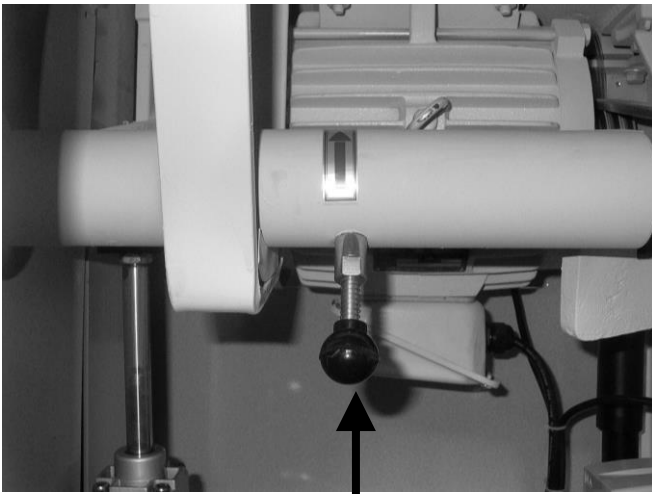

SPINDLE LOCK UNIT

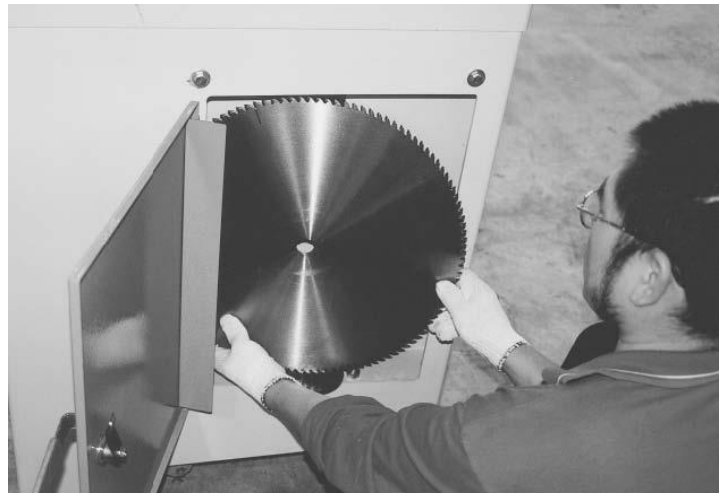

6. Be sure the saw blade teeth point toward its running direction.
7. Tighten the sawblade securely by using the supplied "T" wrench.
8. Reverse above procedures to return the machine to its original condition.

ADJUSTING V-BELT TENSION (1)

After the machine has been operated for a long period, the V-belt tension may loosen gradually. At this time you need to adjust the V-belt tension.

Inadequate tension in the V-belt will cause the belt to slip from the pulley. To adjust V-belt tension:

1. Disconnect the machine from the power source.
2. Slightly loosen the 4 screws on the table.



LOCK SCREW

ADJUSTING V-BELT TENSION (2)

3. Open the front door by using the supplied door handle.
4. Move the motor forward to increase the belt tension.

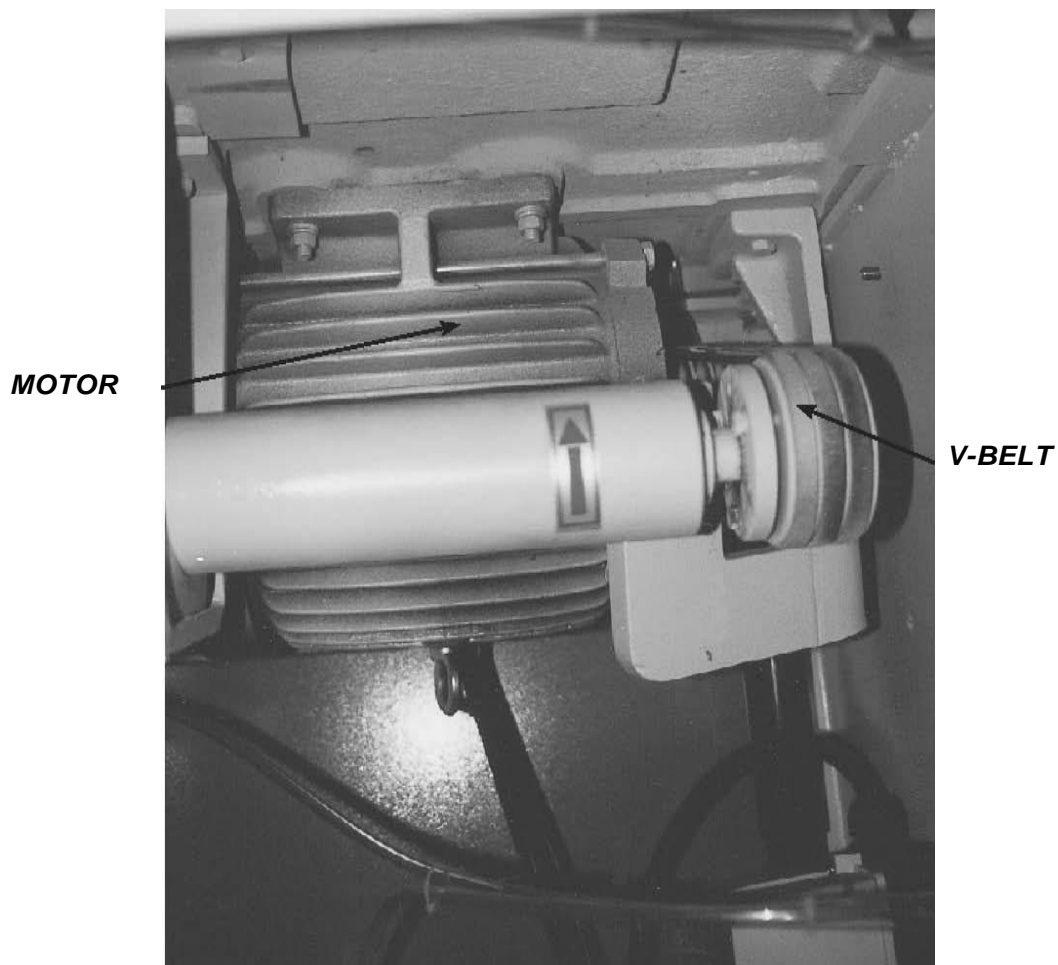

5. After V-belt tension is adjusted tighten the 4 lock screws on the table.

REPLACING V-BELT

If the saw arbor speed decreases or an abnormal sound when starting the sawblade, then it is suggested to replace the V-belt.

When replacing the V-belt, replace the complete three belts to ensure a consistent tension on each belt.

Refer to "ADJUSTING V-BELT TENSION" for V-belt replacement procedures. The V-belt specification is MF-1330.

LUBRICATION

Periodically check the oil amount in lubricator bowl on some parts of cut-off saw which need lubrication:

Parts	Oil Type	Lubricating Interval
Main spindle	Grease	130~150 hours
Rocker lift transmission hand	Grease	30~50 hours
F.R.L. Combination unit.	R32 Cycle Oil	80~150 hours
Sawhead bracket pivot	Grease	Periodically

※ The saw arbor bearings are sealed and need no lubrication.

MAINTENANCE

1. Buildup of saw dust and other debris can cause the machine to cut inaccurately. Periodic cleaning is not only recommended, but mandatory for accurate-cutting.
2. Periodically check the oil in the lubrication cup of the Filter/regulator/lubricator combination unit.
3. Periodically check the water accumulated in the filter cup of the filter/regulator/lubricator combination unit.
4. Clean the saw dust existed on the machine.
5. Periodically to clean scrap of remains on the table, and keep saw blade in sharp condition at all time.

FUNCTIONAL TEST

Those safety devices will be tested functionally.

i) Emergency stop(s) –

Test to be taken at 2~3 week intervals.

ii) Interlocked guards –

Test to be taken at 2~3 week intervals by opening each guard in turn to stop the machine and by proving an inability to start the machine with each guard in the open position.

iii) Guard locking –

Test to be taken at 2~3 week intervals by proving an inability to open the guard as long the saw blade is rotating.

iv) Any light barriers –

Test to be taken at 2~3 week intervals.

v) The brake –

Test to be taken at 2~3 week intervals to check that the machine is braked within the specified time.

TROUBLE SHOOTING

TROUBLE	PROBABLE CAUSES	CORRECTION
SAWBLADE STARTING FAILED	<ol style="list-style-type: none"> 1. Factory power abnormal 2. Power wire damaged 3. Overload thermal pin kick out 	<ol style="list-style-type: none"> 1. Check 2. Replace 3. Press it down
POOR CUTTING QUALITY	<ol style="list-style-type: none"> 1. Sawblade dulled 2. Inaccurate fence alignment 	<ol style="list-style-type: none"> 1. Sharpen sawblade 2. Adjust fence squareness
WORKPIECE BURNT	<ol style="list-style-type: none"> 1. Sawblade dulled 2. Blade teeth worn out or broken 	<ol style="list-style-type: none"> 1. Sharpen sawblade 2. Replace sawblade
SAWBLADE SLOWS DOWN DURING CUTTING	<ol style="list-style-type: none"> 1. Sawblade dulled 2. V-belt tension too loose 3. Blade teeth worn out or broken 	<ol style="list-style-type: none"> 1. Sharpen sawblade 2. Adjust v-belt tension 3. Replace sawblade
MOTOR DOES NOT RUN AT FULL SPEED	<ol style="list-style-type: none"> 1. Power voltage too low 2. Overloaded 	<ol style="list-style-type: none"> 1. Test voltage 2. Reduce load
MOTOR OVERHEATING	<ol style="list-style-type: none"> 1. Motor is dirty 2. Motor is damaged 	<ol style="list-style-type: none"> 1. Clean motor 2. Check and repair motor

SAFETY INTERLOCK SWITCH FUNCTION

(CE SAFETY SWITCH)

The saw blade door is equipped with a CE safety switch (safety interlock switch). The safety interlock switch is with a timer.

When the machine is working, the blade door couldn't be opened.

The timer located in the electrical cabinet is set up around 30~40 seconds.

In order to keep operation safety, after pressing the Off or Emergency switch, there is around 30~40 seconds of waiting time and then the blade door could be opened.

Always shut off the power and wait for the saw blade to completely stop rotating before doing any maintenance, adjustments or changing the saw blade.

**SAFETY INTERLOCK SWITCH
(CE Safety Switch)**

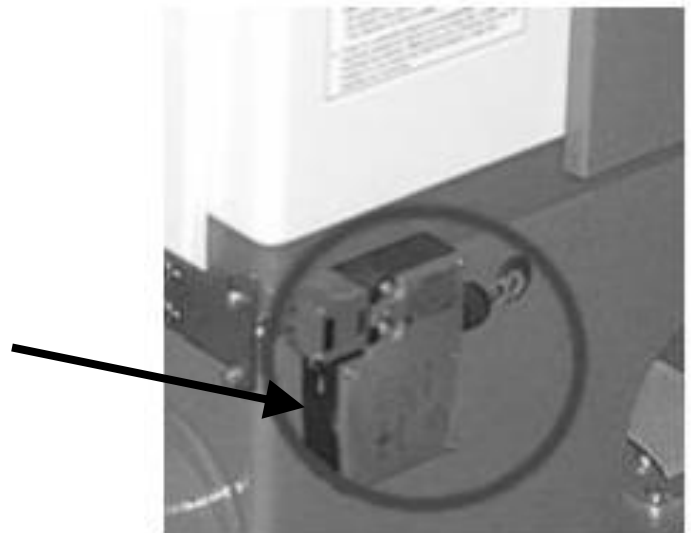

DIAGRAMS AND PART LISTS

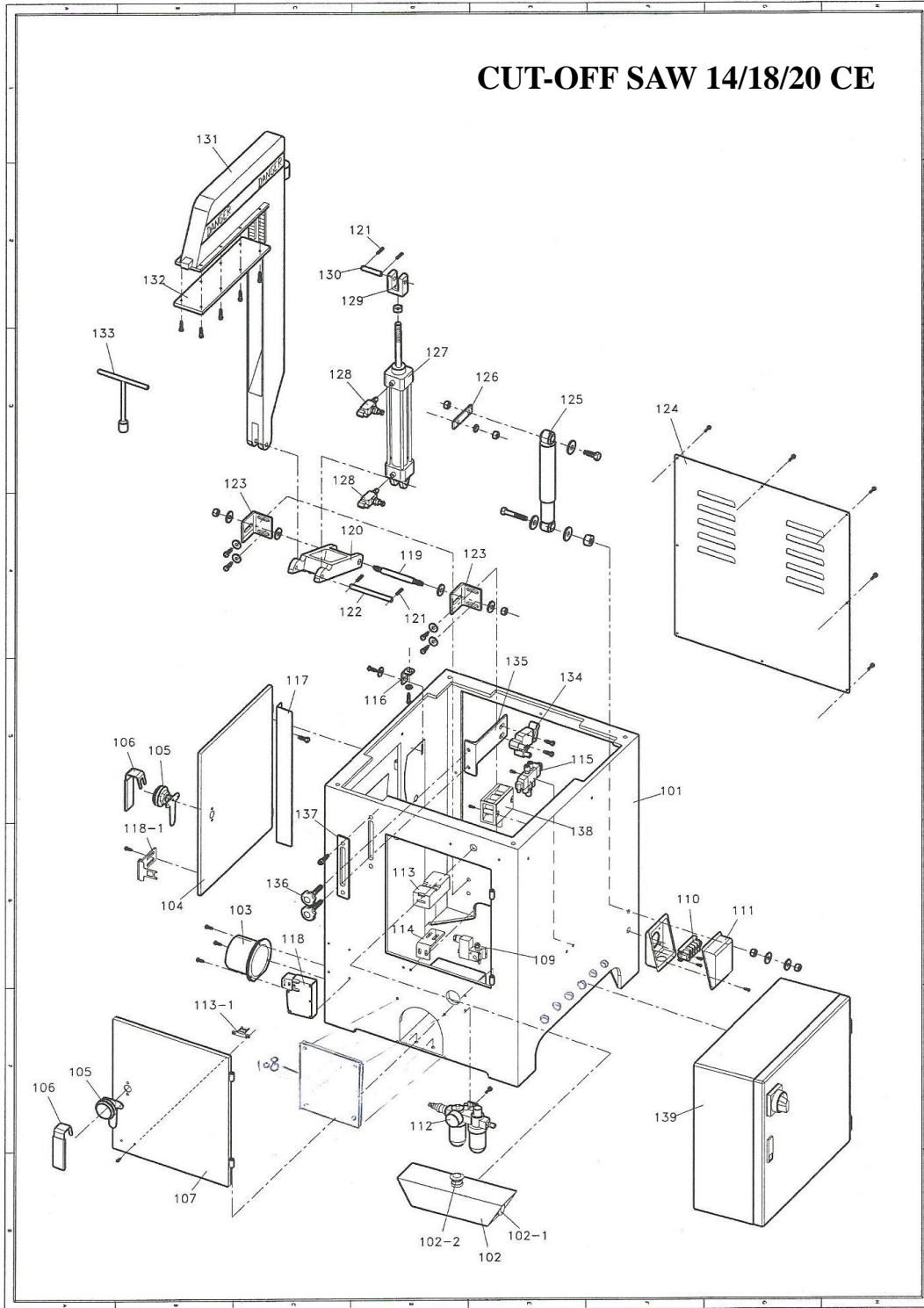

CUT-OFF SAW 20"

REF	DESCRIPTION	Q'TY	REF	DESCRIPTION	Q'TY
101	Cabinet	1	118-1	Fixed Plate	1
102	Two Hand Controls Box	1	119	Stud Bolt	1
102-1	Two Hand Controls	2	120	Support Frame	1
102-2	Emergency Stop	1	121	Split Pin	4
103	Dust Port	1	122	Coupling Pin	1
104	Side Door	1	123	Support Angle Steel	2
105	Door Lock	2	124	Back Door	1
106	Lock Handle	2	125	Cushion	1
107	Front Door	1	126	Connecting Link	1
108	Plate	1	127	Air Cylinder	1
109	Solenoid Valve	1	128	Pressure Regulating Valve	2
110	Wire Connecting Plate	1	129	Toggle	1
111	Electrical Box	1	130	Coupling Pin 1/2" x 2"	1
112	Air filter- pressure Regulator – oil feeder	1	131	T-clamp	1
113	CE Pin	1	132	Gasket	1
113-1	Front Door Switch Pin AZD-11	1	133	Socket Wrench 19mm	1
114	Fixed Plate	1	134	Limit Switch	1
115	Air Valve	2	135	Limit Switch Bracket	1
116	Bracket	1	136	Adjustable Handle	2
117	L Iron Plate for side door	1	137	Adjustable Plate	1
118	CE Safety Switch	1	138	0.1 Sec. Safety Module	1

CUT-OFF SAW 14/18/20 CE

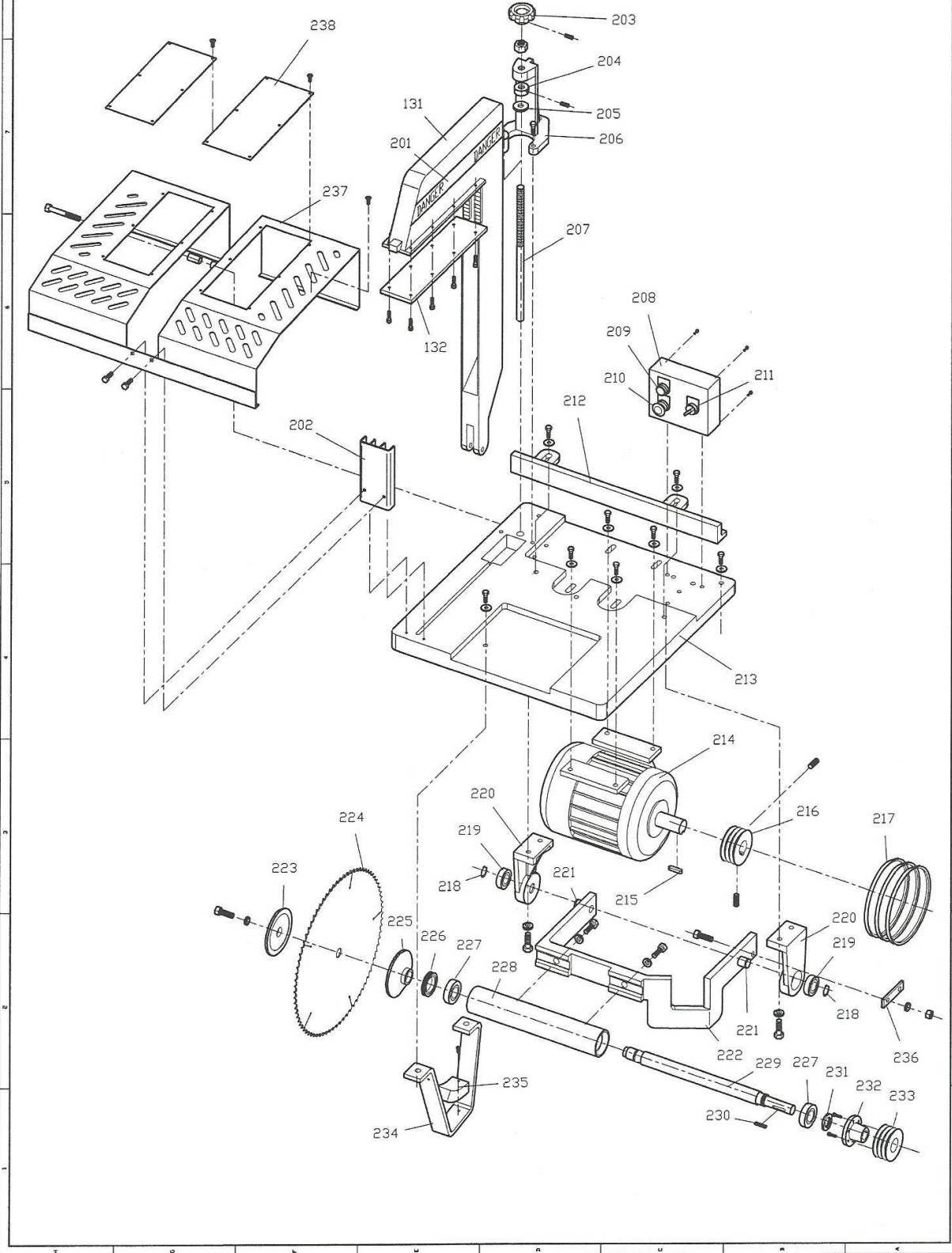

CUT-OFF SAW 20"

REF	DESCRIPTION	Q'TY	REF	DESCRIPTION	Q'TY
201	Danger Label	2	223	Flange Washer	1
202	Safety Appurtenance	1	224	Saw Blade	1
203	Adjusting Hand Wheel	1	225	Inside Flange	1
204	Lock Nut	1	226	Locknut	1
205	Rubber Ring	1	227	Bearing 6206zz	2
206	Adjustable Seat	1	228	Quill	1
207	Guide Screw	1	229	Main Spindle	1
208	Switch Box	1	230	Key	1
209	On Button	1	231	Locknut-left	1
210	Off Button	1	232	Tapper Flange	1
211	Air Inlet Switch	1	233	Drive Pulley	1
212	Fence	1	234	Lower Bracket	1
213	Table	1	235	Lower Damper	1
214	Motor	1	237	Safety Guard	1
215	Key	1	238	Acrylic Sheet	2
216	Motor Pulley	1			
217	V-belt MF1330	3			
218	C-ring	2			
219	Bearing 6205zz	2			
220	Bracket	2			
221	Shaft	2			
222	Suspension Bran	1			